

Drift 500 & 750 Pendants - USA



Resident

# CONTENTS

Technical Specification - Drift 500	3
Technical Specification - Drift 750	4
Installation & Driver Instructions - Drift 500	5
Installation & Driver Instructions - Drift 750	6
Alternative Drivers	7
Ceiling Rose - Standard	8
Ceiling Plate - Alternative	9
Links	10

# Drift Pendant - 500

Michael Young | 2025

The Drift pendant is a study in purity and precision, its mathematically formed silhouette designed to distribute light evenly across its entire surface. Available in two sizes, Drift can stand alone or be grouped in clusters, each angle revealing a new facet of its shifting form. Inspired by pebble stone paving, Drift is suited to both residential and commercial settings, its refined presence quietly enhancing each space with gentle, ethereal illumination.



## MATERIALS

Translucent Polymer on PPE Structure

## CEILING ROSE

Matt Black Aluminium

## PRODUCT ENVIRONMENT

Indoor Use Only

## CONTRACT USE

Yes

## CERTIFICATION

CE, RCM, ETL

## WARRANTY

3 years

## COUNTRY OF ORIGIN

China

## CODE

DFT001

## PRODUCT

Drift Pendant - 500

## LIGHT SOURCE

Integrated LED

## VOLTAGE

36V

## POWER USAGE

12W

## LUMENS

1000lm

## COLOUR TEMP

2700k

## CRI

90

## LIFESPAN

50,000Hrs

## CABLE

Min 30 cm (12 in) - Max 500 cm (118 in)

## DIMMING

The Drift Pendant is dimmable as standard and comes with a Triac driver. Alternate dimming options available on request.

## FINISHES

white



## PRODUCT WEIGHT

2kg (4.4lbs)

## PACKAGED DIMENSIONS

L x W x H	Cubage	Weight
Box 1		
60 x 60 x 25cm	0.09m <sup>3</sup>	4kg
23.6 x 23.6 x 9.8 in	8.8ft <sup>3</sup>	3.2lbs

## COMMODITY CODE

9405423990

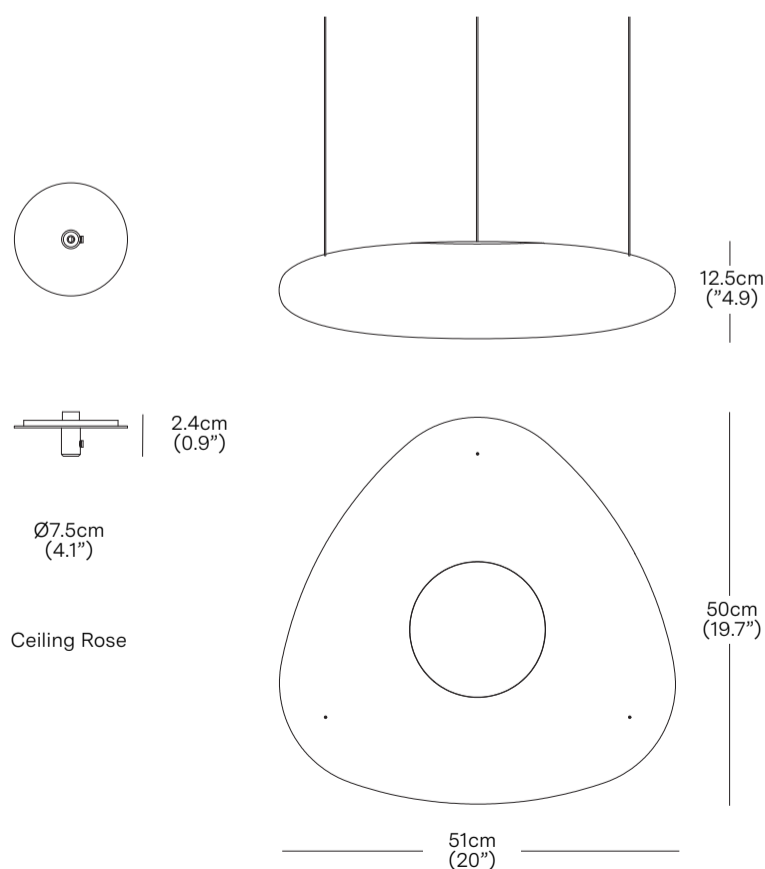

\* Components drawn in relative scale. Refer to CAD files for accurate drawings.

# Drift Pendant - 750



Michael Young | 2025

The Drift pendant is a study in purity and precision, its mathematically formed silhouette designed to distribute light evenly across its entire surface. Available in two sizes, Drift can stand alone or be grouped in clusters, each angle revealing a new facet of its shifting form. Inspired by pebble stone paving, Drift is suited to both residential and commercial settings, its refined presence quietly enhancing each space with gentle, ethereal illumination.

## MATERIALS

Translucent Polymer on PPE Structure

## CEILING ROSE

Matt Black Aluminium

## PRODUCT ENVIRONMENT

Indoor Use Only

## CONTRACT USE

Yes

## CERTIFICATION

CE, RCM, ETL

## WARRANTY

3 years

## COUNTRY OF ORIGIN

China

## CODE

DFT002

## PRODUCT

Drift Pendant - 750

## LIGHT SOURCE

Integrated LED

## VOLTAGE

36V

## POWER USAGE

12W

## LUMENS

1000lm

## COLOUR TEMP

2700k

## CRI

90

## LIFESPAN

50,000Hrs

## CABLE

Min 30 cm (12 in) - Max 500 cm (118 in)

## DIMMING

The Drift Pendant is dimmable as standard and comes with a Triac driver. Alternate dimming options available on request.

## FINISHES

white



## PRODUCT WEIGHT

5.8kg (12.8lbs)

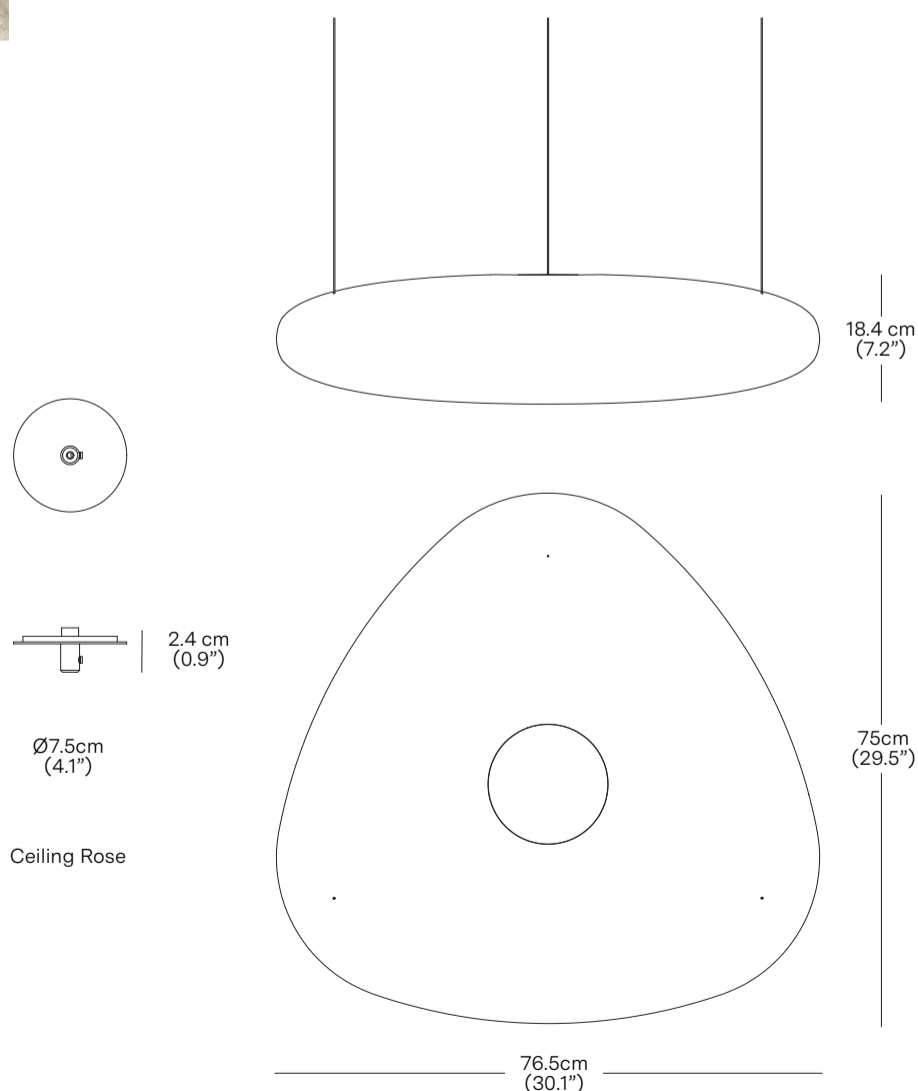

\* Components drawn in relative scale. Refer to CAD files for accurate drawings.

## PACKAGED DIMENSIONS

L x W x H	Cubage	Weight
Box 1		
87 x 87 x 30cm	0.23m3	10kg
34.3 x 34.3 x 11.8 in	8.0ft3	22.1lbs

## COMMODITY CODE

9405423990

**Resident**

# Installation Instructions - Drift Pendant 500

## Resident

### Drift Pendant Instructions - US

Product Code: DFT001



Warning, installation must be completed by a certified Electrician only.

#### Assembly Kit Contents:

- 1 x Drift Pendant 500
- 9 x Wood Screws
- 1 x Driver
- 3 x Ceiling Rose Face Plates
- 3 x Ceiling Brackets
- 3 x Threaded Suspension Nuts
- 3 x Grubscrews
- 4 x Wire Nuts

This pendant is an LED luminaire, which requires an external driver to provide a 24V electricity source. The driver included in your purchase is dimmable.

**1** The pendant can hang a minimum of 4" and a maximum distance of 196" from the ceiling. To install the pendant follow the instructions below:

- Connect the Black positive cable from the input side of the Driver to the incoming mains Live wire using the twist-on Wire Nuts
- Connect the White negative cable from the input side of the Driver to the incoming mains Neutral wire using the twist-on Wire Nuts

\*note the connections to the driver must be inside a UL rated junction box supplied by the electrician, this box will be secured into a ceiling cavity above the pendant.

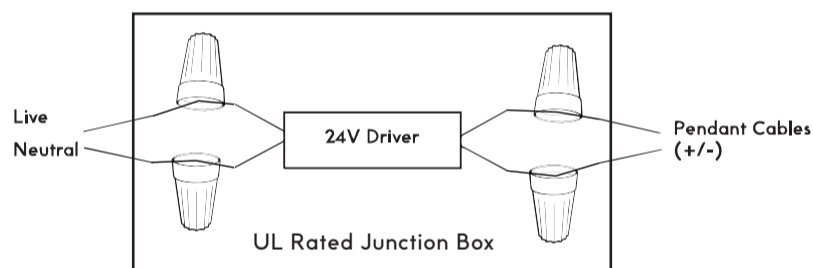

**2** To space the three ceiling roses correctly. The cables should be positioned to fall vertically from the pendant to the ceiling. This guide can help with spacing the ceiling roses correctly.

\*note the distance between each cable is not the same

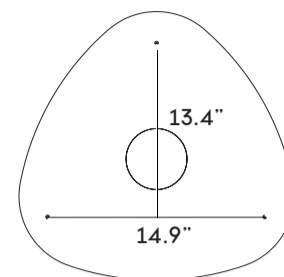

**3** • To mount the ceiling rose first screw each ceiling bracket with the countersunk side facing down using the Wood Screws.

• Feed the cable up through the Threaded Suspension Nut and through the Ceiling Rose Face Plate into the Ceiling Bracket.

• Screw the Threaded Suspension Nut into the ceiling bracket with the faceplate inbetween. Screw the plastic Grubscrew into the side of the Suspension Nut to secure the pendant.

• Adjust the height and leveling of the pendant via the Grubscrew.

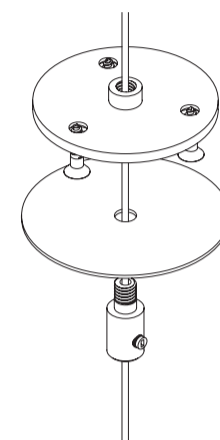

**4** Trim Excess wire if required.

- Connect the Red cable on the outgoing side of the driver to the positive pendant cable using the twist-on Wire Nuts
- Connect the Yellow cable on the outgoing side of the driver to the negative pendant cable using the twist-on Wire Nuts

\*note there are three cables on this pendant, one of these is a null cable

Pendant is now installed

Product Care + Warranty available at [www.resident.co.nz](http://www.resident.co.nz)

## Drift Pendant 500 Driver - Supplied

DRIFT 500 & 750 Pendants come standard with a 12W Triac (Dimable) Driver It is to be located in the ceiling cavity or junction box

- Description: Hoshingmei constant current dimmer LED driver.  
 Model: HC-013035LDF.  
 Input: 220-240V AC, 50/60Hz.  
 Output: 350mA DC constant current.  
 Power Rating: 9-13W (maximum) - it is pre set to 12W  
 Features: Dimmable with leading and trailing edge dimmers. Designed for SELV (Safety Extra Low Voltage) applications.



# Installation Instructions - Drift Pendant 750

## Resident

### Drift Pendant Instructions - US

Product Code: DFT002



Warning, installation must be completed by a certified Electrician only.

#### Assembly Kit Contents:

- 1 x Drift Pendant 750
- 9 x Wood Screws
- 1 x Driver
- 3 x Ceiling Rose Face Plates
- 3 x Ceiling Brackets
- 3 x Threaded Suspension Nuts
- 3 x Grubscrews
- 4 x Wire Nuts

This pendant is an LED luminaire, which requires an external driver to provide a 24V electricity source. The driver included in your purchase is dimmable.

**1** The pendant can hang a minimum of 4" and a maximum distance of 196" from the ceiling. To install the pendant follow the instructions below:

- Connect the Black positive cable from the input side of the Driver to the incoming mains Live wire using the twist-on Wire Nuts
- Connect the White negative cable from the input side of the Driver to the incoming mains Neutral wire using the twist-on Wire Nuts

\*note the connections to the driver must be inside a UL rated junction box supplied by the electrician, this box will be secured into a ceiling cavity above the pendant.

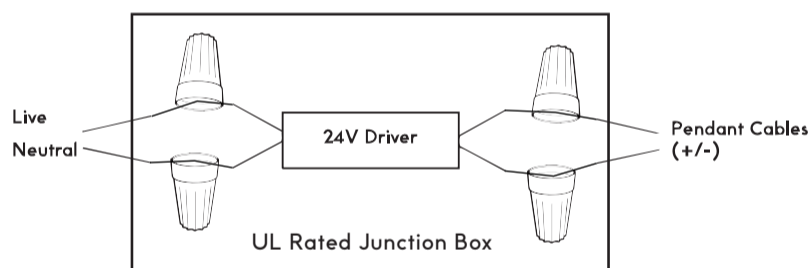

**2** To space the three ceiling roses correctly. The cables should be positioned to fall vertically from the pendant to the ceiling. This guide can help with spacing the ceiling roses correctly.

\*note the distance between each cable is not the same

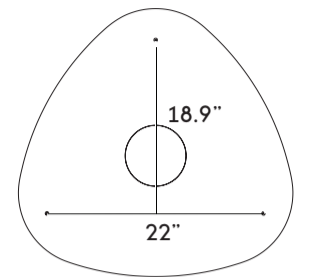

**3** • To mount the ceiling rose first screw each ceiling bracket with the countersunk side facing down using the Wood Screws.

• Feed the cable up through the Threaded Suspension Nut and through the Ceiling Rose Face Plate into the Ceiling Bracket.

• Screw the Threaded Suspension Nut into the ceiling bracket with the faceplate inbetween. Screw the plastic Grubscrew into the side of the Suspension Nut to secure the pendant.

• Adjust the height and leveling of the pendant via the Grubscrew.

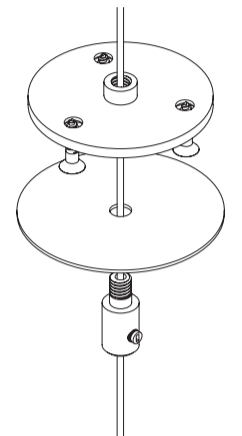

**4** Trim Excess wire if required.

- Connect the Red cable on the outgoing side of the driver to the positive pendant cable using the twist-on Wire Nuts
- Connect the Yellow cable on the outgoing side of the driver to the negative pendant cable using the twist-on Wire Nuts

\*note there are three cables on this pendant, one of these is a null cable

Pendant is now installed

Product Care + Warranty available at [www.resident.co.nz](http://www.resident.co.nz)

## Drift Pendant 750 Driver - Supplied

DRIFT 500 & 750 Pendants come standard with a 12W Triac (Dimable) Driver It is to be located in the ceiling cavity or junction box

- Description: Hoshingmei constant current dimmer LED driver.  
 Model: HC-013035LDF.  
 Input: 220-240V AC, 50/60Hz.  
 Output: 350mA DC constant current.  
 Power Rating: 9-13W (maximum) - it is pre set to 12W  
 Features: Dimmable with leading and trailing edge dimmers. Designed for SELV (Safety Extra Low Voltage) applications.



## 0-10V Dimming - Additional Purchase

The LED driver is a separate purchase. It converts mains AC power into a stable, low-voltage constant current, It is to be located in the ceiling cavity or junction box, replacing the driver supplied with the light.

DFT101	Drift 500, 0-10V dimmer (set driver to 300mA)
DFT102	Drift 750, 0-10V dimmer (set driver to 350mA)
Description:	Novbo LED Driver (Constant Current, 0-10V Dimmable)
Function:	Converts high-voltage AC input to a stable, low-voltage constant current for LED fixtures.
Input:	AC Mains Input
Output:	Output: 300 or 350mA Constant Current / 15W
Control:	0-10V dimming input (DIM+ / DIM- terminals) for compatible dimmer switch



Do not use a standard phase-cut (household) dimmer switch/controller. A compatible 0-10V dimmer switch/controller is required

---

## Dali Relay Module - Additional Purchase

The Dali Relay Module is a separate purchase. This sits between the Dali System and the above standard Drift driver. It is to be located in the ceiling cavity or junction box

DFT100	Drift Dali Relay Converter
Description:	Sunricher SR-2701S-DT7 DALI Relay Module.
Function:	DALI Relay Module
Input:	DALI Input (DA, DA)
Load Capacity:	Relay Load 300/1000W
Control:	Managed by DALI controlled and powered by DALI.



---

## Multiple Pendants on One Driver - Electrician Supply

Load Capacity:	Multiple Drift Pendants can be powered by a single driver.
Driver Specifications:	Use a constant-current dimming driver noting Drift 500 requires 300mA and Drift 750 requires 350mA per light
Wiring:	Connect in parallel only, series connection is strictly prohibited.
Sourcing:	This solution is not provided by Resident. Any components must be sourced and installed by a certified electrician.

# Drift Ceiling Rose - Supplied

Read the full assembly instructions prior to installation.

Each Drift pendant light comes with three pre-attached cables, each cable has its own ceiling rose plate.

This means you will be installing three ceiling plates - one for each cable.

This design ensures the pendant hangs neatly, with straight, vertically aligned, parallel cables.

The driver should be placed within the ceiling cavity, (similar to installing a downlight).

The two power cables connect to the driver, which is then connected to the mains power supply.

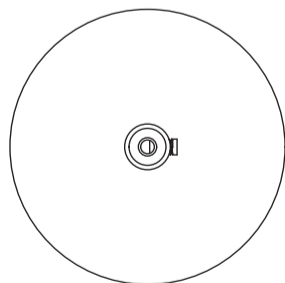
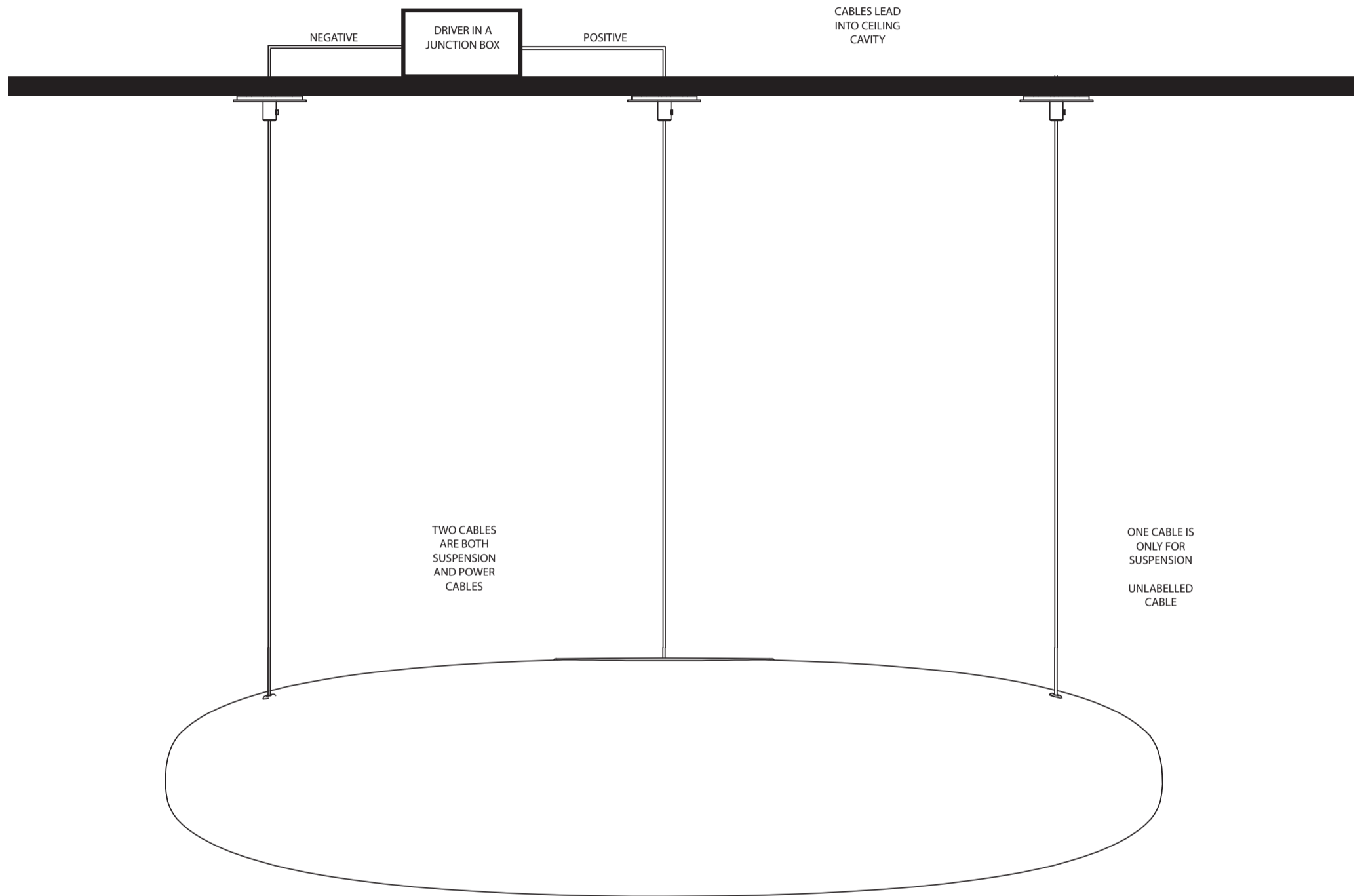

Ø7.5cm  
(4.1")

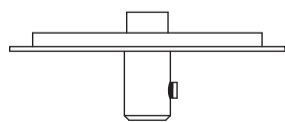

2.4cm  
(0.9")

# Drift Ceiling Plate - Additional Purchase

This is an alternative option Resident can provide on request.

It includes a single large ceiling plate, available in a powder-coated finish (standard colours are black or white).

It is available in 2 diameters 51cm or 71cm,

This option is ideal for wooden or concrete ceilings where the ceiling cavity is not accessible and conduit may be required.

The plate can also be installed on a sloped ceiling, with adjustments to ensure the cables remain straight and evenly aligned.

DFT02 Drift Ceiling Rose - 500

DFT03 Drift Ceiling Rose - 750

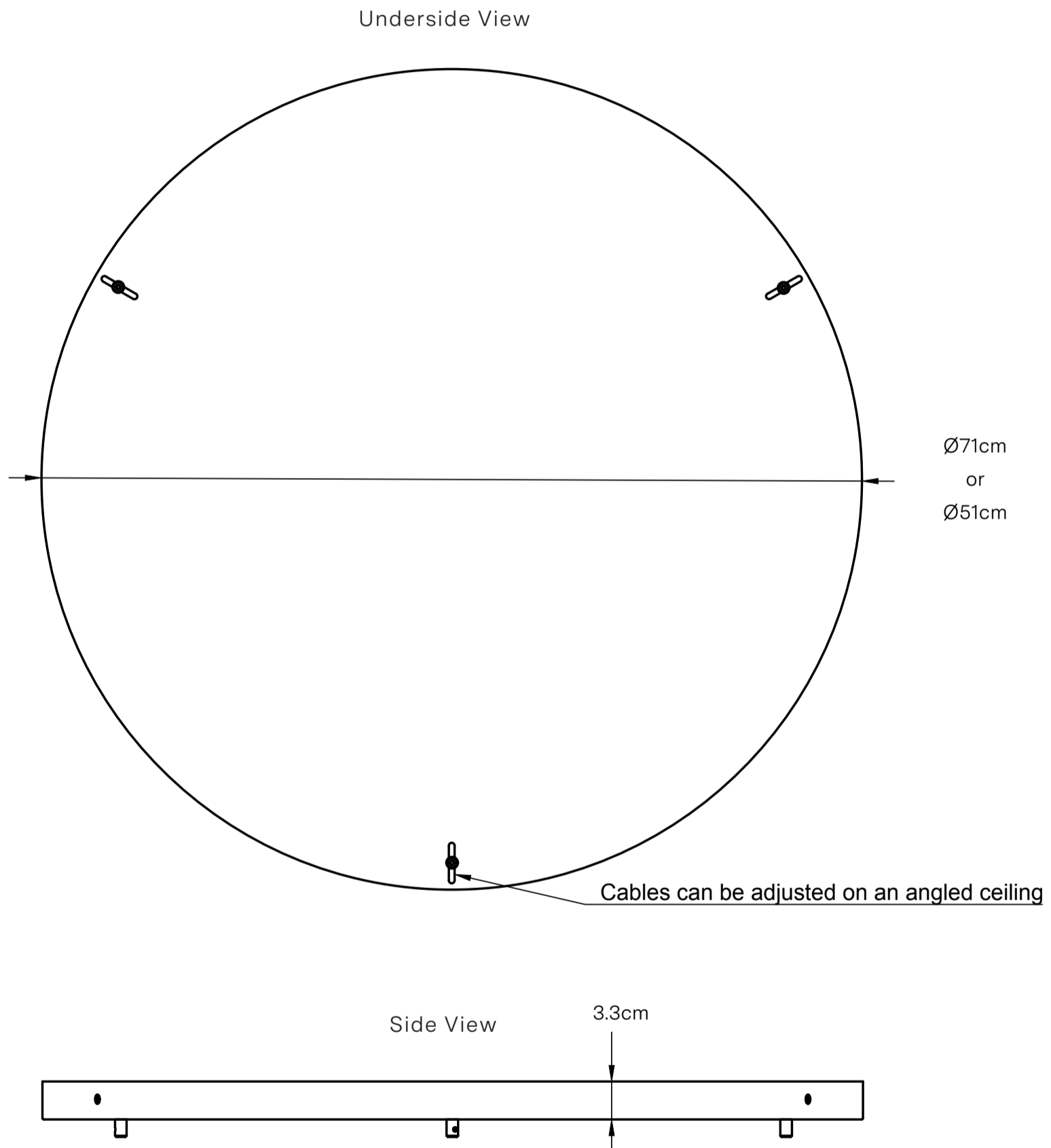

# LINKS

Technical Specification - Drift 500

[https://drive.google.com/file/d/1ngBUMesSGkpJ58cHsWmECSnwBjJh6MQR/view?usp=drive\\_link](https://drive.google.com/file/d/1ngBUMesSGkpJ58cHsWmECSnwBjJh6MQR/view?usp=drive_link)

Technical Specification - Drift 750

[https://drive.google.com/file/d/1\\_u7vTJXDcnUdaZVFHEVYMVgaV0QScBHB/view?usp=drive\\_link](https://drive.google.com/file/d/1_u7vTJXDcnUdaZVFHEVYMVgaV0QScBHB/view?usp=drive_link)

Installation & Driver Instructions - Drift 500, USA Version

[https://drive.google.com/file/d/19Hq5W8gEXAxHC4Mlzkdw7BF87-bG7lf1/view?usp=drive\\_link](https://drive.google.com/file/d/19Hq5W8gEXAxHC4Mlzkdw7BF87-bG7lf1/view?usp=drive_link)

Installation & Driver Instructions - Drift 750, USA Version

[https://drive.google.com/file/d/1slkeMglxLjYw3AWgJgblubMa\\_S\\_eksMD/view?usp=drive\\_link](https://drive.google.com/file/d/1slkeMglxLjYw3AWgJgblubMa_S_eksMD/view?usp=drive_link)

